

**LiFeBATT DEMONSTRATION SYSTEM KIT AVAILABLE FOR ORDER NOW!
INCLUDES (3) P 18 BATTERY PACKS WITH VMS AND IM + SOFTWARE**

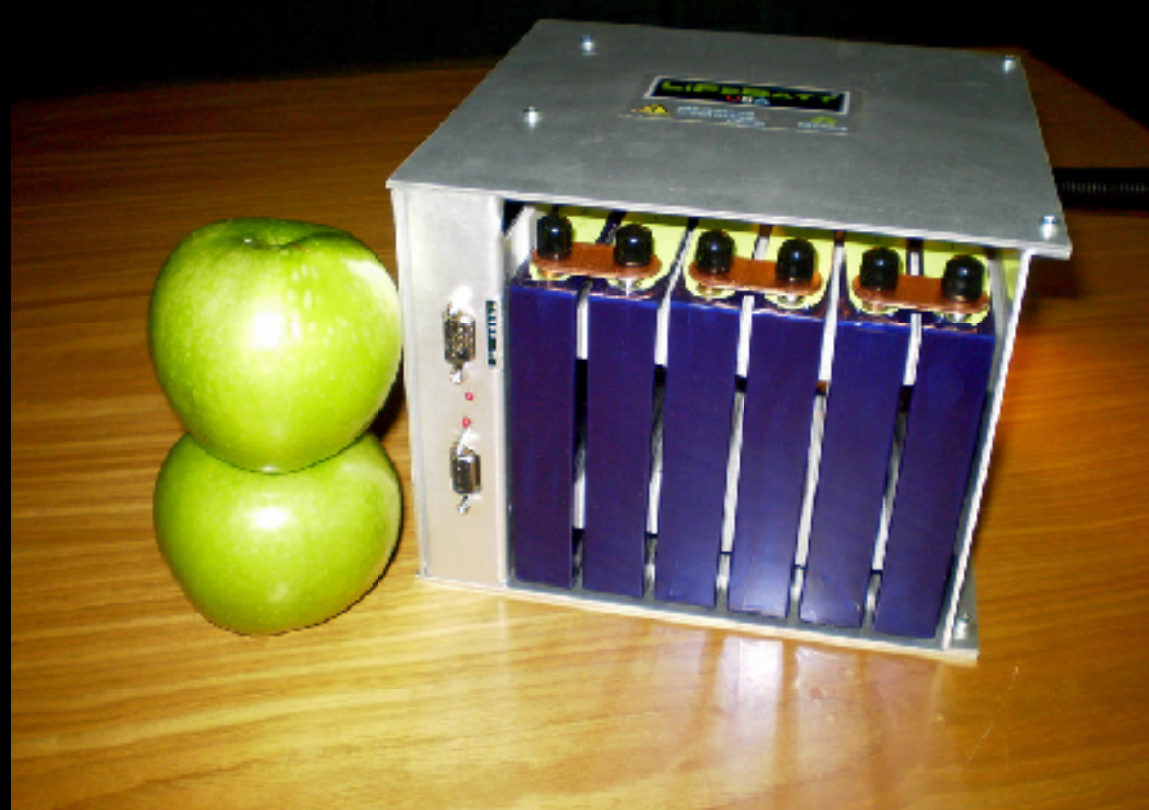

P 18 - 13.2V / 108Ah PRISMATIC SKELETON SYSTEM (3) PACKS ALSO AVAILABLE WIRED FOR P 18 - 79.2V / 18Ah

SIDE VIEW PACK AND UNIVERSAL CONTROL BOX

13.2V / 36Ah P18 BATTERY PACK (8 CELLS) OR
26.4V / 18Ah P18 BATTERY PACK (8 CELLS).

NOTE: THIS KIT OFFERS ENGINEERS THE CHANCE TO EVALUATE ALL THE FEATURES OF LIFE BATT'S SMART BATTERY SYSTEM. THE KIT INCLUDES BATTERIES, A FULL FEATURED HIGH SPEED VMS AND AN INTEGRATION MODULE (IM) WITH SUPPORTING SOFTWARE AND ALL CABLE CONNECTIONS.

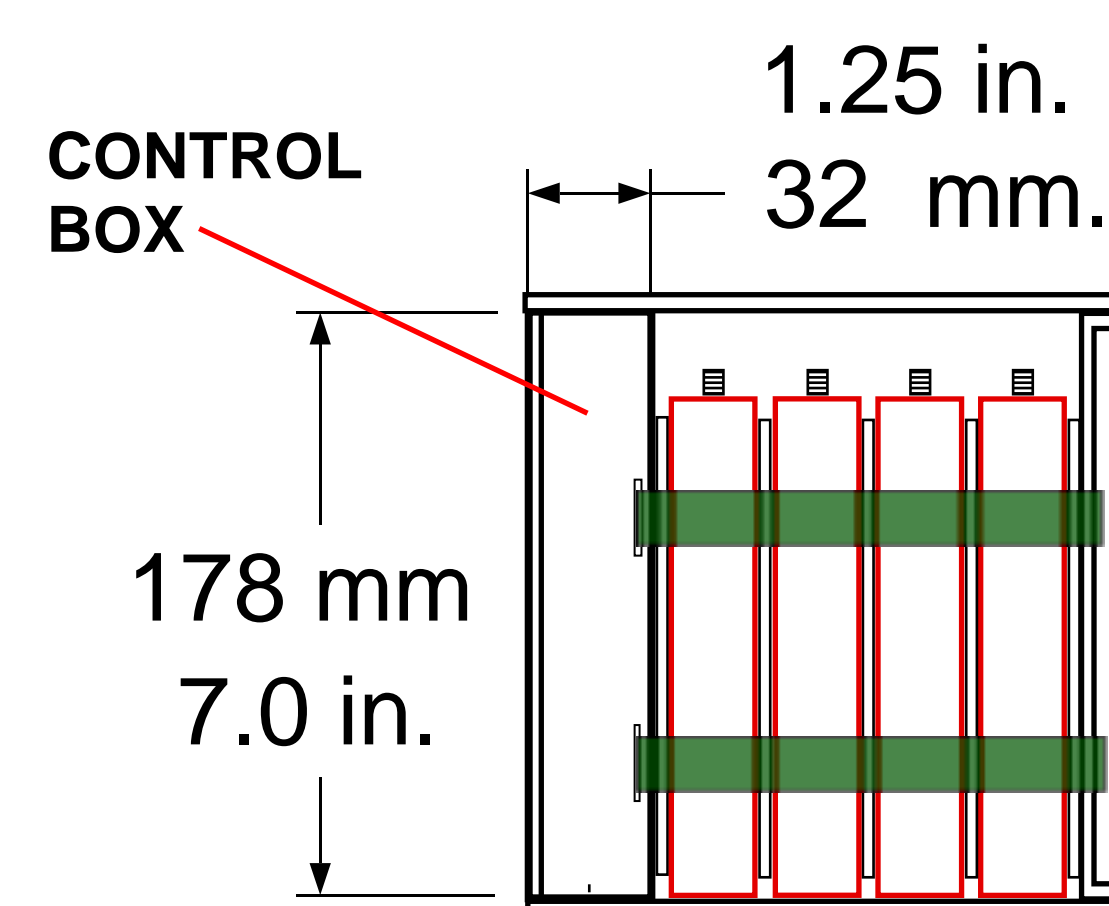

WEIGHT PER PACK = 10 LBS.

TOP VIEW BATTERY BANK WITH ALUMINUM COVER PLATES

NOTE: Easy Access For Changing Out One Pack In The System.

PRICE FOR KIT INCLUDING IM MODULE FOR FULL SYSTEM DIAGNOSTICS: \$ 2,812.00 INCL. DELIVERY. ALL DATA PORT CABLES & SOFTWARE INCLUDED.

CONTROL BOX - OPEN

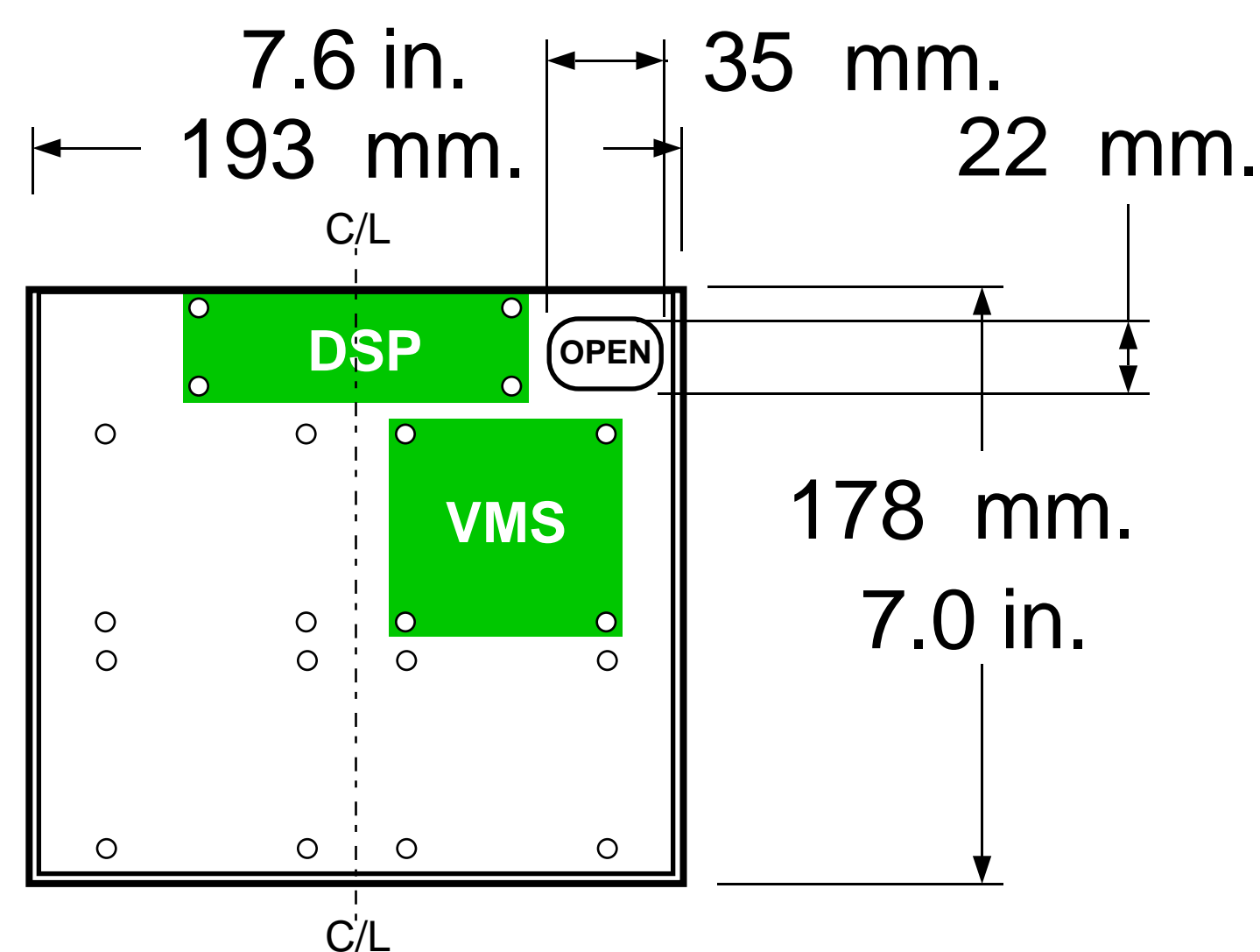

OUTSIDE DIMENSIONS

